



Geeya 捷雅

A stylized logo consisting of two parallel, slightly curved lines. The top line is dashed and colored in a mix of blue and orange. The bottom line is solid and colored in a mix of orange and red. The lines are positioned above and below the text 'Geeya 捷雅'.



每一天，我们提供优质的产品让车友驰骋在世界每个角落。进取、求新是捷雅追求完美的代名词。捷雅车业是一家专业生产自行车零部件的厂家，主要致力于拨链器以及控制器、刹车器、定位飞轮等系列产品的开发与生产，在国内外享有很高的声誉。为了不断创新，提高产品质量及零部件的整体性能，升华变速系统的舒适理念，迎合各种休闲自行车的骑行风格，公司配备了专业的技术研发队伍，制定了严格的科学管理体系，引进了先进的生产工艺，创造了人性化的工作环境，让捷雅人在面对日益强劲的竞争力时，对前景充满信心。捷雅的发展目标是把一流的产品与一流的服务奉献给各界朋友，在过去的岁月，承蒙朋友们的鼎力支持，捷雅才有辉煌，而今，捷雅更需要你们一如既往的呵护，你们才是捷雅的坚强后盾。

Everyday, Geeya's excellent products let riding friends enjoy galloping every corner in the world. firmly determined, enterprising spirit, innovation are our synonym to go for perfect.

Cixi Geeya Bicycle Co., Ltd. is a professional manufacturer of bicycle parts, who always focus attention on developing & producing high-grade derailleurs, shifting levers, brakes, index freewheels etc., the brand of "LINGXIANG" "RnR" are enjoying high reputation both at domestic and overseas. In order to continue innovating new designs, improving quality & overall performance of products, sublimating the comfortable idea of transmission and cater to riding styles of various leisure bicycles, we allocate professional RD technicians, formulate strict and scientific management system, introduce advanced process technology and create humanized working environment, which let Geeya have enough confidence to face stronger competition.

Our goal is bring first-rate products and service to each friend. In the past, Geeya has refulgence owe to support with your kind effort, nowadays, we need your cherish as always, because you are our forever strong backing.



SO
good
TO HEAR
from you

GEE

20
19



production & equipment

ya

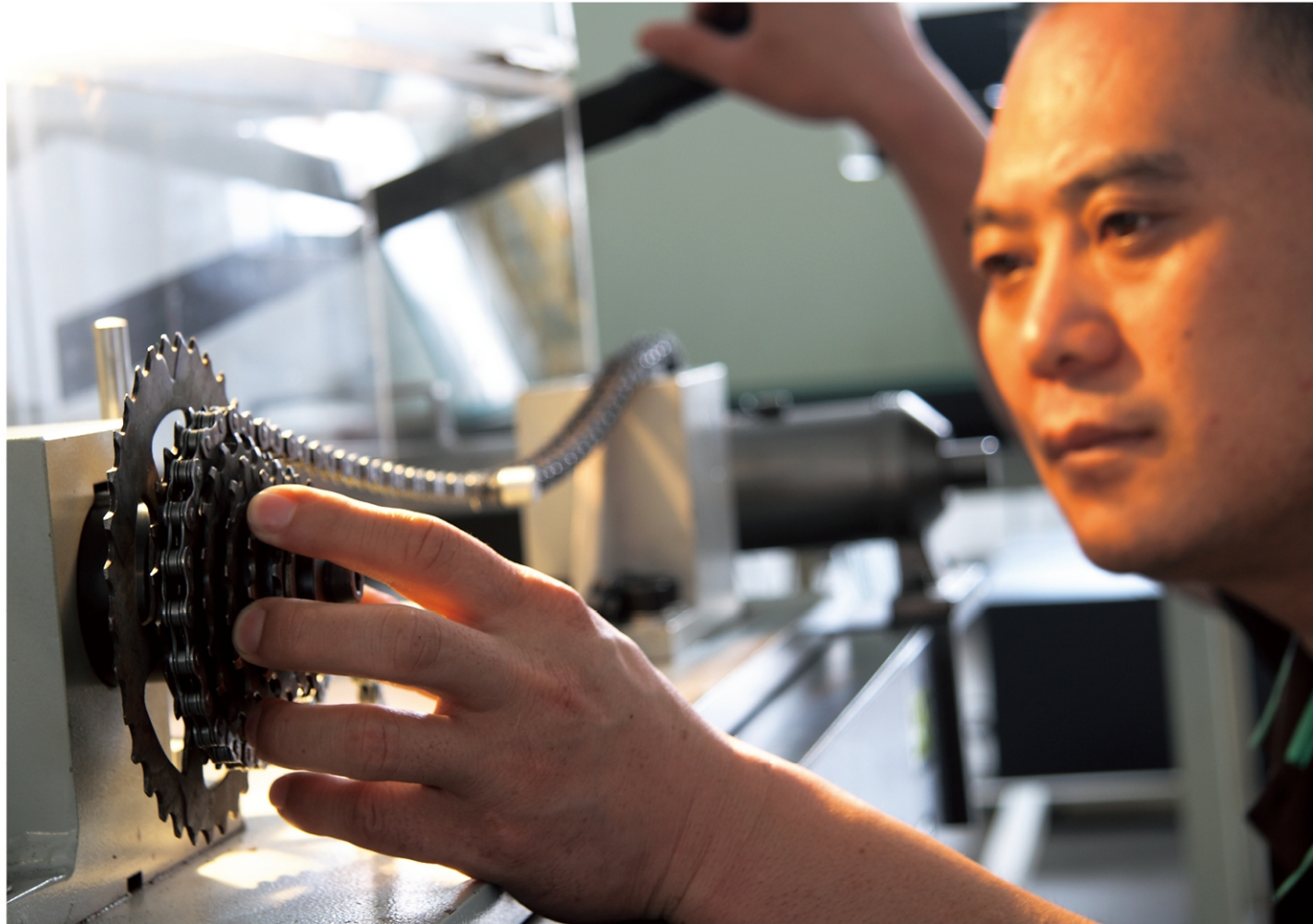

捷雅以质量立足市场，以创新求得发展，凭借公司长期精心科研和先进的管理理念，并利用精良的生产和检测设备不断地将精品推向市场。我们用心做到每点每滴都在为客户创造更大的价值，真正体现“您身边的传动专家”的美好愿望和创业理想。我们坚持走专业化道路，以领先的技术，过硬的品质，完善周到的服务赢得市场。捷雅的团队正在竭尽全力创造一流的产品，以期引领行业发展。



Geeya keeps foothold in the market by excellent quality, and developing by creative ability. With company's long-term elaborating researches & advanced management concepts, and using sophisticated production & testing equipments to push the high-quality products to the market. We work hard in every aspects to create greater values for our customers, really reflect the good wishes & entrepreneurial ideas of "transmission expert around you". We stick to the professional road to win the market by leading technology, excellent quality & perfect service. Jieya's team is doing best to create first-class products to lead the industry.

GEE



production & equipment

捷雅始终将“诚、和、创”作为企业经营理念，并贯彻于企业的每一个环节。诚，就是要求我们忠诚于每个企业，忠诚于客户；和，就是要求我们和睦相处，和衷共济；创，就是要求我们不断创新，全面创新、恒久创新。Geeya always carries out the operating philosophy of “integrity, harmony & innovation” into each link in the enterprise. “Integrity” is ask us to be loyal to our company and customers; “Harmony” is living together in unity; “Innovation” is keeping bring forth new ideas continuously.



先进的检测设备使公司能够全面掌握从原材料到加工工艺的有效检测方法，确保零部件生产的质量可靠性。我们追求精品工程，以人为本，采用台湾精益生产的管理方式，推行全面质量管理，抓系统、抓细节，力争产品零缺陷。Advanced testing equipments let us grasp effective test methods from raw materials to processing technology, and ensure quality reliability of components. We pursue quality engineering & put people first, and use excellent production management ideas of Taiwan to implement the overall quality control, detail focus, and strive to be zero defects.

ya

CONTENTS

P15 FRONT DERAILLEUR
前拨链器

P19 REAR DERAILLEUR
后拨链器

P25 SHIFTING LEVER
调速控制器

P30 GRIP
把套

P32 FREEWHEEL
飞轮

P43 BRAKE SETS
闸器

P47 OTHER ACCESSORIES
其它配件



10 Speed Index System LX-510



LXC-40
Digital Index Shifter
定位数显控制器



LXC-38
定位数显控制器
Digital Index Shifter



LXCS-10I-42T
10 Speed Index cassette sprockets
10速定位卡式飞轮



LXA-44
Index Rear Derailleur
定位后拨



LXB-21
Index Front Derailleur
定位前拨

9 Speed Index System LX-509



LXC-35
定位数显控制器
Digital Index Shifter



LXC-38
定位数显控制器
Digital Index Shifter



LXA-41
定位后拨
Index Rear Derailleur



FW-6209BK
9速定位卡式飞轮
Index 9 Speed Cassette freewheel



LXFW-9SICP
9速定位飞轮
9 Speed Index Freewheel



LXA-37
定位后拨
Index Rear Derailleur



LXB-14
定位前拨
Index Front Derailleur



LXB-19
定位前拨
Index Front Derailleur

8 Speed Index System LX-508

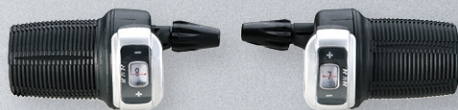

LXC-37
定位视窗旋转控制器
Windows Index Grip Shifter



LXC-35
定位数显控制器
Digital Index Shifter



LXA-43
定位后拨
Index Rear Derailleur



LXFW-8S1B/BK
8速定位飞轮
8 Speed Index Freewheel



FW-6108CP
8速定位卡式飞轮
Index 8 Speed Cassette freewheel



LXA-42
定位后拨
Index Rear Derailleur



LXB-14
定位前拨
Index Front Derailleur



LXB-11
定位前拨
Index Front Derailleur

7 Speed Index System LX-507



LXC-22
单定位旋转控制器
Single Index Grip Shifter



LXC-33
定位旋转控制器
Index Twist Shifter



LXB-15
定位前拨
Index Front Derailleur



LXFW-7SICP
7速定位飞轮
7 Speed Index Freewheel



LXFW-7SIAB/BK
7速定位飞轮
7 Speed Index Freewheel



LXA-26
定位后拨
Index Rear Derailleur



LXA-09
定位后拨
Index Rear Derailleur

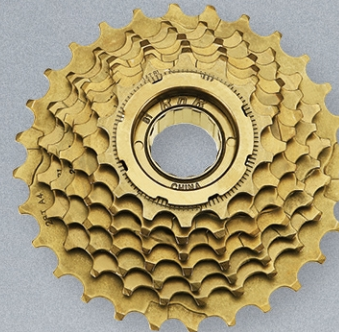

LXFW-7SIB
7速定位飞轮
7 Speed Index Freewheel



LXB-18
定位前拨
Index Front Derailleur

6 Speed Index System LX-506



LXC-29
定位旋转控制器
Index Twist Shifter



LXC-15
定位旋转控制器
Index Twist Shifter



LXA-08
定位后拨
Index Rear Derailleur



LXFW-65ICP
6速定位飞轮
6 Speed Index Freewheel



LXFW-65IB
6速定位飞轮
6 Speed Index Freewheel



LXA-32
定位后拨
Index Rear Derailleur



LXB-05
定位前拨
Index Front Derailleur



LXA-31
定位后拨
Index Rear Derailleur



LXB-01
非定位前拨
Non-Index Front Derailleur

Non-Index System LX-505



LXC-07
摩擦式旋转控制器
Friction Grip Shifter



LXS-02
MTB / ATB 摩擦式调速控制器
MTB / ATB Friction Shifting Lever



LXS-05
MTB / ATB非定位调速控制器
MTB / ATB Non-Index Thumb Shifter



LXFW-55
5速非定位飞轮
5 Speed Non-Index Freewheel



LXC-25
摩擦式旋转控制器
Friction Grip Shifter



LXFW-65
6速非定位飞轮
6 Speed Non-Index Freewheel



LXFW-75
7速非定位飞轮
7 Speed Non-Index Freewheel



LXA-03
非定位后拨
Non-Index Rear Derailleur



LXB-03
非定位前拨
Non-Index Front Derailleur



LXB-01
非定位前拨
Non-Index Front Derailleur



LXA-05
非定位后拨
Non-Index Rear Derailleur



LXA-01
非定位后拨
Non-Index Rear Derailleur

2019

FRONT DERAILLEUR

/

GEEYA BICYCLE

No.18, Niniu Tang Rd., Shengshan, Cixi, Ningbo,

+

前 拨链器。

|

轻巧、紧凑型驱动的特别设计，调整螺钉角度，用螺丝刀轻松调节，真正从骑行者的角度出发，实现最佳的变速效果。

In order to achieve the best effect of variable speed and consider from the point of riders, we design the light & compact drive and change the screw's angle in order to adjust the screw easily by screwdriver.





LXB-21

Index Front Derailleur

定位前拨

Dual pull

Suitable for triple or quadruple chainwheel

Aluminum bracket & Black steel clamp

Clamp diam: 31.8mm / 34.9mm

Capacity: 22T Top gear: 42T

Packing: 50pcs/ctn, 38x25x19cm, G.W.:10kgs

上下拉兼容 拨链数: 3-4片 铝合金束座

安装直径: 31.8mm / 34.9mm

总容量: 22T, 最大链轮齿数: 42T



LXB-14

Index Front Derailleur

定位前拨

Dual pull

Suitable for triple or quadruple chainwheel

Aluminum bracket & Black steel clamp

Clamp diam: 31.8mm / 34.9mm

Capacity: 22T Top gear: 48T

Packing: 50pcs/ctn, 38x25x19cm, G.W.:10kgs

上下拉兼容 拨链数: 3-4片 铝合金束座

安装直径: 31.8mm / 34.9mm

总容量: 22T, 最大链轮齿数: 48T



LXB-19

Index Front Derailleur

定位前拨

Dual pull

Suitable for triple or quadruple chainwheel

Aluminum bracket & clamp

Clamp diam: 31.8mm / 34.9mm

Capacity: 20T Top gear: 44T

Packing: 50pcs/ctn, 38x25x19cm, G.W.:10kgs

上下拉兼容 拨链数: 3-4片 铝合金束座

安装直径: 31.8mm / 34.9mm

总容量: 20T, 最大链轮齿数: 44T



LXB-11

Index Front Derailleur

定位前拨

Dual pull

Suitable for triple or quadruple chainwheel

Steel clamp diam: 28.6mm / 31.8mm

Capacity: 20T Top gear: 42T

Packing: 50pcs/ctn, 35x25x19cm, G.W.:10kgs

上下拉兼容 拨链数: 3-4片

钢制夹环, 安装直径: 28.6mm / 31.8mm

总容量: 20T, 最大链轮齿数: 42T



LXB-07

Index Front Derailleur

定位前拨

Dual pull

Suitable for triple or quadruple chainwheel

Steel clamp diam: 28.6mm / 31.8mm

Capacity: 22T Top gear: 48T

Packing: 50pcs/ctn, 38x25x19cm, G.W.:10kgs

上下拉兼容 拨链数: 3-4片

钢制夹环, 安装直径: 28.6mm / 31.8mm

总容量: 22T, 最大链轮齿数: 48T

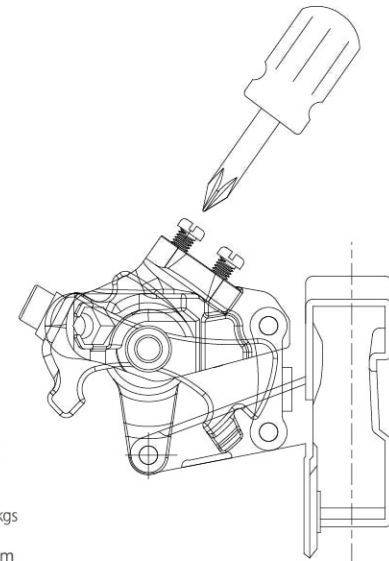

**LXB-12**

Index Front Derailleur 定位前拨

Down pull

Suitable for triple chainwheel

Steel clamp diam: 28.6mm / 31.8mm

Capacity: 20T Top gear: 42T

Packing: 100pcs/ctn, 46x25x18cm, G.W.:15kgs

下拉 拨链数: 3片

钢制夹环, 安装直径: 28.6mm / 31.8mm

总容量: 20T, 最大链轮齿数: 42T

**LXB-18**

Index Front Derailleur 定位前拨

Down pull

Suitable for triple or quadruple chainwheel

Steel clamp diam: 28.6mm / 31.8mm

Capacity: 22T Top gear: 48T

Packing: 100pcs/ctn, 47x26x18cm, G.W.:15kgs

下拉 拨链数: 3-4片

钢制夹环, 安装直径: 28.6mm / 31.8mm

总容量: 22T, 最大链轮齿数: 48T

**LXB-05**

Index Front Derailleur 定位前拨

Down pull

Suitable for triple chainwheel

Steel clamp diam: 28.6mm / 31.8mm

Capacity: 20T Top gear: 42T

Packing: 100pcs/ctn, 46x25x18cm, G.W.:15kgs.

下拉 拨链数: 3片

钢制夹环, 安装直径: 28.6mm / 31.8mm

总容量: 20T, 最大链轮齿数: 42T

**LXB-13**

Index Front Derailleur 定位前拨

Top pull

Suitable for triple chainwheel

Steel clamp diam: 28.6mm / 31.8mm

Capacity: 20T Top gear: 42T

Packing: 100pcs/ctn, 46x25x18cm, G.W.:15kgs

上拉 拨链数: 3片

钢制夹环, 安装直径: 28.6mm / 31.8mm

总容量: 20T, 最大链轮齿数: 42T

**LXB-10**

Index Front Derailleur 定位前拨

Top pull

Suitable for triple or quadruple chainwheel

Steel clamp diam: 28.6mm / 31.8mm

Capacity: 22T Top gear: 48T

Packing: 100pcs/ctn, 46x25x18cm, G.W.:15kgs

上拉 拨链数: 3-4片

钢制夹环, 安装直径: 28.6mm / 31.8mm

总容量: 22T, 最大链轮齿数: 48T

**LXB-06**

Index Front Derailleur 定位前拨

Top pull

Suitable for triple chainwheel

Steel clamp diam: 28.6mm / 31.8mm

Capacity: 20T Top gear: 42T

Packing: 100pcs/ctn, 46x25x18cm, G.W.:15kgs

上拉 拨链数: 3片

钢制夹环, 安装直径: 28.6mm / 31.8mm

总容量: 20T, 最大链轮齿数: 42T



LXB-20

Index Front Derailleur 定位前拨

Down pull

Suitable for triple or quadruple chainwheel

Steel clamp diam: 28.6mm / 31.8mm

Capacity: 22T Top gear: 48T

Packing: 100pcs/ctn, 46x25x18cm, G.W.:15kgs

下拉, 拨链数: 3-4片

钢制夹环, 安装直径: 28.6mm / 31.8mm

总容量: 22T, 最大链轮齿数: 48T



LXB-15

Index Front Derailleur 定位前拨

Down pull

Suitable for triple or quadruple chainwheel

Steel clamp diam: 28.6mm/31.8mm

Capacity: 20T Top gear: 42T

Packing: 100pcs/ctn, 46x25x18cm, G.W.:15kgs

下拉 拨链数: 3-4片

钢制夹环, 安装直径: 28.6mm/31.8mm

总容量: 20T, 最大链轮齿数: 42T



LXB-01

Non-Index Front Derailleur

非定位前拨

Down pull

Suitable for triple or quadruple chainwheel

Steel clamp diam: 28.6mm / 31.8mm

Capacity: 22T Top gear: 48T

Packing: 100pcs/ctn, 46x25x18cm, G.W.:15kgs

下拉, 拨链数: 3-4片

钢制夹环, 安装直径: 28.6mm / 31.8mm

总容量: 22T, 最大链轮齿数: 48T

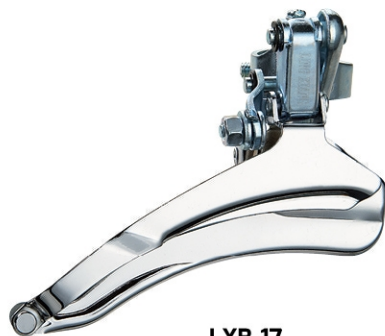

LXB-17

Index Front Derailleur 定位前拨

Top pull

Suitable for triple or quadruple chainwheel

Steel clamp diam: 28.6mm / 31.8mm

Capacity: 22T Top gear: 48T

Packing: 100pcs/ctn, 46x25x18cm, G.W.:15kgs.

上拉, 拨链数: 3-4片

钢制夹环, 安装直径: 28.6mm / 31.8mm

总容量: 22T, 最大链轮齿数: 48T



LXB-03

Non-Index Front Derailleur 非定位前拨

Down pull

Suitable for double chainwheel

Steel clamp diam: 28.6mm / 31.8mm

Capacity: 20T Top gear: 48-52T

Packing: 100pcs/ctn, 46x25x18cm, G.W.:15kgs

下拉, 拨链数: 2片

钢制夹环, 安装直径: 28.6mm / 31.8mm

总容量: 20T, 最大链轮齿数: 48-52T



LXB-02

Non-Index Front Derailleur 非定位前拨

Top pull

Suitable for triple or quadruple chainwheel

Steel clamp diam: 28.6mm / 31.8mm

Capacity: 22T Top gear: 48T

Packing: 100pcs/ctn, 46x25x18cm, G.W.:15kgs

上拉, 拨链数: 3-4片

钢制夹环, 安装直径: 28.6mm / 31.8mm

总容量: 22T, 最大链轮齿数: 48T

2019

REAR DERAILLEUR

/

GEEYA BICYCLE

No.18, Niniu Tang Rd., Shengshan, Cixi, Ningbo,

+

后 拨链器。

|

高性能零部件，融合“轻巧、平稳”的设计理念，带来轻松可靠的骑行感觉。

The high performance parts & light and stable design concept, which bring us relaxed and reliable feeling of riding.





LXA-44

Index Rear Derailleur
定位后拨
Long Cage for 27/30 speed
Direct installation.
Feature: Steel & Resin
Capacity: 45T, Tyre tread: 99.6mm
Packing: 50pcs/ctn, 49x28x20cm
G.W.: 17kgs
长臂, 适用于27/30速
直接安装
特征: 钢制及树脂组合
齿容量: 43T, 导轮间距: 98mm



LXA-41

Index Rear Derailleur
定位后拨
Long Cage for 27 speed
Direct installation.
Feature: Aluminum alloy, Steel & Resin
Capacity: 45T, Tyre tread: 99.6mm
Packing: 50pcs/ctn, 49x28x20cm
G.W.: 17kgs
长臂, 适用于27速
直接安装
特征: 铝合金, 钢制及树脂组合
齿容量: 45T, 导轮间距: 99.6mm



LXA-43

Index Rear Derailleur
定位后拨
Long Cage for 24 speed
Direct installation.
Feature: Aluminum alloy, Steel & Resin
Capacity: 45T, Tyre tread: 99.6mm
Packing: 50pcs/ctn, 49x28x20cm
G.W.: 17kgs
长臂, 适用于24速
直接安装
特征: 铝合金, 钢制及树脂组合
齿容量: 45T, 导轮间距: 99.6mm



LXA-37

Index Rear Derailleur
定位后拨
Long Cage for 27 speed
Direct installation.
Feature: Alloy aluminum, Steel & Resin
Capacity: 45T, Tyre tread: 89mm
Packing: 50pcs/ctn, 49x28x20cm
G.W.: 17kgs
长臂, 适用于27速
直接安装
特征: 铝合金, 钢制及树脂组合
齿容量: 45T, 导轮间距: 89mm



LXA-42

Index Rear Derailleur
定位后拨
Long Cage for 21-24 speed
Direct installation.
Feature: Steel & Resin
Capacity: 43T, Tyre tread: 75mm
Packing: 50pcs/ctn, 49x28x20cm
G.W.: 17kgs
长臂, 适用于21-24速
直接安装
特征: 钢制及树脂组合
齿容量: 43T, 导轮间距: 75mm



LXA-27

Index Rear Derailleur
定位后拨
Long Cage for 21/24 speed
Direct installation.
Feature: Steel & Resin
Capacity: 45T, Tyre tread: 99.6mm
Packing: 50pcs/ctn, 49x28x20cm
G.W.: 17kgs
长臂, 适用于21/24速
直接安装
特征: 钢制及树脂组合
齿容量: 45T, 导轮间距: 99.6mm



LXA-25

**Index Rear Derailleur
定位后拨**
Short Cage for 21 speed
Direct installation.
Feature: Aluminum alloy, Steel & Resin
Capacity: 43T, Tyre tread: 65mm
Packing: 50pcs/ctn, 46x26x21cm
G.W.: 16kgs
短臂, 适用于21速
直接安装
特征: 铝合金, 钢制及树脂组合
齿容量: 43T, 导轮间距: 65mm



LXA-26

**Index Rear Derailleur
定位后拨**
Short Cage for 21 speed
Direct installation.
Feature: Steel & Resin
Capacity: 43T, Tyre tread: 65mm
Packing: 50pcs/ctn, 46x26x21cm
G.W.: 16kgs
短臂, 适用于21速
直接安装
特征: 钢制及树脂组合
齿容量: 43T, 导轮间距: 65mm



LXA-38

**Index Rear Derailleur
定位后拨**
Long Cage for 21 speed
Bracket installation
Feature: Steel & Resin
Capacity: 43T, Tyre tread: 75mm
Packing: 50pcs/ctn, 49x26x17cm
G.W.: 16kgs
长臂, 适用于21速
接片安装
特征: 钢制及树脂组合
齿容量: 43T, 导轮间距: 75mm



LXA-09

**Index Rear Derailleur
定位后拨**
Long Cage for 21 speed
Bracket installation.
Feature: Steel & Resin
Capacity: 43T, Tyre tread: 86mm
Packing: 50pcs/ctn, 49x26.5x17cm
G.W.: 16kgs
长臂, 适用于21速
接片安装
特征: 钢制及树脂组合
齿容量: 43T
导轮间距: 86mm



LXA-21

**Index Rear Derailleur
定位后拨**
Long Cage for 18-21 speed
Bracket installation.
Feature: Steel & Resin
Capacity: 36T, Tyre tread: 75mm
Packing: 50pcs/ctn, 49x26x17cm
G.W.: 16kgs
长臂, 适用于18-21速
接片安装
特征: 钢制及树脂组合
齿容量: 36T
导轮间距: 75mm



LXA-22

**Index Rear Derailleur
定位后拨**
Long Cage for 18-21 speed
Direct installation.
Feature: Steel & Resin
Capacity: 36T, Tyre tread: 75mm
Packing: 50pcs/ctn, 49x26x17cm
G.W.: 16kgs
长臂, 适用于18-21速
直接安装
特征: 钢制及树脂组合
齿容量: 36T
导轮间距: 75mm



LXA-11

Index Rear Derailleur
定位后拨
Long Cage for 21 speed
Bracket installation.
Feature: Steel & Resin
Capacity: 36T
Packing: 50pcs/ctn, 49x26x17cm
G.W.:16kgs
长臂, 适用于21速
接片安装
特征: 钢制及树脂组合
齿容量: 36T



LXA-31

Index Rear Derailleur
定位后拨
Long Cage for 18-21 speed
Bracket installation.
Feature: Steel & Resin
Capacity: 36T
Packing: 50pcs/ctn, 42x24x16cm
G.W.: 15.5kgs
长臂, 适用于18-21速
接片安装
特征: 钢制及树脂组合
齿容量: 36T



LXA-32

Index Rear Derailleur
定位后拨
Long Cage for 18-21 speed
Direct installation.
Feature: Steel & Resin
Capacity: 36T
Packing: 50pcs/ctn, 42x24x16cm
G.W.: 15.5kgs
长臂, 适用于18-21速
直接安装
特征: 钢制及树脂组合
齿容量: 36T



LXA-12

Index Rear Derailleur
定位后拨
Long Cage for 21 speed
Direct installation.
Feature: Steel & Resin
Capacity: 36T
Packing: 50pcs/ctn, 49x26x17cm
G.W.: 16kgs
长臂, 适用于21速
直接安装
特征: 钢制及树脂组合
齿容量: 36T



LXA-40

Index Rear Derailleur
定位后拨
Short Cage for 12-15 speed
Bracket installation.
Feature: Steel & Resin
Capacity: 28T
Packing: 50pcs/ctn, 40x24x16cm
G.W.: 14kgs
短臂, 适用于12-15速
接片安装
特征: 钢制及树脂组合
齿容量: 28T



LXA-39

Index Rear Derailleur
定位后拨
Short Cage for 12-15 speed
Direct installation.
Feature: Steel & Resin
Capacity: 28T
Packing: 50pcs/ctn, 40x24x16cm
G.W.: 14kgs
短臂, 适用于12-15速
直接安装
特征: 钢制及树脂组合
齿容量: 28T



LXA-18

**Index Rear Derailleur
定位后拨**
Long Cage for 18-21 speed
Bracket installation.
Feature: Steel & Resin
Capacity: 36T
Tyre tread: 75mm
Packing: 50pcs/ctn, 42x24x16cm
G.W.: 15.5kgs
长臂, 适用于18-21速
接片安装
特征: 钢制及树脂组合
齿容量: 36T
导轮间距: 75mm



LXA-07

**Index Rear Derailleur
定位后拨**
Long Cage for 18 speed
Bracket installation.
Feature: Steel & Resin
Capacity: 36T
Packing: 50pcs/ctn, 42x24x16cm
G.W.: 15.5kgs
长臂, 适用于18速
接片安装
特征: 钢制及树脂组合
齿容量: 36T



LXA-08

**Index Rear Derailleur
定位后拨**
Long Cage for 18 speed
Bracket installation.
Feature: Steel & Resin
Capacity: 36T
Tyre tread: 75mm
Packing: 50pcs/ctn, 42x24x16cm
G.W.: 15.5kgs
长臂, 适用于18速
接片安装
特征: 钢制及树脂组合
齿容量: 36T
导轮间距: 75mm



LXA-17

**Index Rear Derailleur
定位后拨**
Long Cage for 18-21 speed
Direct installation.
Feature: Steel & Resin
Capacity: 36T, Tyre tread: 75mm
Packing: 50pcs/ctn, 42x26x17cm
G.W.: 16kgs
长臂, 适用于18-21速
直接安装
特征: 钢制及树脂组合
齿容量: 36T
导轮间距: 75mm



LXA-01

**Non-Index Rear Derailleur
非定位后拨**
长臂, 适用于18-21速
Bracket installation.
Feature: Steel & Resin
Capacity: 36T
Tyre tread: 75mm
Packing: 50pcs/ctn, 42x24x16cm
G.W.: 15.5kgs
长臂, 适用于18-21速
接片安装
特征: 钢制及树脂组合
齿容量: 36T
导轮间距: 75mm



LXA-02

**Non-Index Rear Derailleur
非定位后拨**
长臂, 适用于18-21速
Direct installation.
Feature: Steel & Resin
Capacity: 36T
Tyre tread: 75mm
Packing: 50pcs/ctn, 42x24x16cm
G.W.: 15.5kgs
长臂, 适用于18-21速
直接安装
特征: 钢制及树脂组合
齿容量: 36T
导轮间距: 75mm



LXA-06

Non-Index Rear Derailleur
非定位后拨
Short Cage for 12-15 speed
Bracket installation.
Feature: Steel & Resin
Capacity: 28T
Tyre tread: 57mm
Packing: 50pcs/ctn
40x24x16cm, G.W.:14kgs
短臂, 适用于12-15速
接片安装
特征: 钢制及树脂组合
齿容量: 28T
导轮间距: 57mm



LXA-05

Non-Index Rear Derailleur
非定位后拨
Short Cage for 12-15 speed
Direct installation.
Feature: Steel & Resin
Capacity: 28T
Tyre tread: 57mm
Packing: 50pcs/ctn, 40x24x16cm
G.W.:14kgs
短臂, 适用于12-15速
直接安装
特征: 钢制及树脂组合
齿容量: 28T
导轮间距: 57mm



LXA-35

Electric Bicycle Tightener
电动车张紧器
Short Cage
Thick guide pulley
12-holes direct installation
短臂
电动车专用加厚导轮
12孔轴直接安装



LXA-36

Electric Bicycle Tightener
电动车张紧器
Short Cage
Thick guide pulley
Frame direct installation.
短臂
电动车专用加厚导轮
车架直接安装

2019

SHIFTING LEVER

/
GEEYA BICYCLE

No.18, Niniu Tang Rd., Shengshan, Cixi, Ningbo,

+

调速 控制器。

|
干脆的定位感觉和精确的变速。
SMOOTH INDEX AND ACCURATE SPEED.





LXC-35

Digital Index Shifter
定位数显控制器
Left: 3 speed
Right: 7 / 8 / 9 / 10 speed
Material: Aluminum alloy
Clamp diam: 22.2mm
Packing: 50sets/ctn 46x36x24cm G.W.: 17kgs
左边: 3速 右边: 7 / 8 / 9 / 10 速
材质: 铝合金 安装直径: 22.2mm



LXC-36

Digital Index Shifter
定位数显控制器
Left: 3 speed
Right: 7 / 8 / 9 / 10 speed
Material: Aluminum alloy
Clamp diam: 22.2mm
Packing: 50sets/ctn 46x36x24cm G.W.: 17kgs
左边: 3速 右边: 7 / 8 / 9 / 10 速
材质: 铝合金 安装直径: 22.2mm



LXC-40

Digital Index Shifter
定位数显控制器
Left: 3 speed
Right: 7 / 8 / 9 / 10 speed
Material: Aluminum alloy
Clamp diam: 22.2mm
Packing: 50sets/ctn 46x36x24cm G.W.: 17kgs
左边: 3速 右边: 7 / 8 / 9 / 10 速
材质: 铝合金 安装直径: 22.2mm



LXC-38

Digital Index Shifter
定位数显控制器
Left: 3 speed
Right: 8 / 9 / 10 speed
Material: Aluminum alloy
Clamp diam: 22.2mm
Packing: 50sets/ctn 46x36x24cm G.W.: 17kgs
左边: 3速 右边: 8 / 9 / 10 速
材质: 铝合金 安装直径: 22.2mm



LXC-37

Windows Index Grip Shifter

定位视窗旋转控制器

Left: 3 speed / Non-index

Right: 7 / 8 / 9 speed

Material: Resin

Clamp diam: 22.2mm

Packing: 50sets/ctn, 47x25x25cm

G.W.: 13.5kgs

左边: 3速 / 非定位 右边: 7 / 8 / 9 速

材质: 树脂, 安装直径: 22.2mm



LXC-13

Windows Index Twist Shifter

定位视窗旋转控制器

Left: 3 speed / Non-index

Right: 6 / 7 speed

Material: Resin

Clamp diam: 22.2mm

Packing: 50sets/ctn, 49x26x26cm

G.W.: 16kgs

左边: 3速 / 非定位 右边: 6 / 7 速

材质: 树脂 安装直径: 22.2mm



LXC-26

Windows Index Twist Shifter

定位视窗旋转控制器

Left: 3 speed / Non-index

Right: 6 / 7 speed

Material: Resin

Clamp diam: 22.2mm

Packing: 50sets/ctn 49x26x26cm

G.W.: 16kgs

左边: 3速 / 非定位 右边: 6 / 7 速

材质: 树脂 安装直径: 22.2mm



LXC-33

Index Twist Shifter

定位旋转控制器

Left: 3 speed / Non-index

Right: 6 / 7 speed

Material: Resin

Clamp diam: 22.2mm

Packing: 50sets/ctn, 47x25x25cm

G.W.: 14.5kgs

左边: 3速 / 非定位, 右边: 6 / 7 速

材质: 树脂, 安装直径: 22.2mm



LXC-29

Index Twist Shifter

定位旋转控制器

Left: 3 speed / Non-index

Right: 6 / 7 speed

Material: Resin

Clamp diam: 22.2mm

Packing: 50sets/ctn, 47x25x25cm

G.W.: 13.5kgs

左边: 3速 / 非定位, 右边: 6 / 7 速

材质: 树脂, 安装直径: 22.2mm



LXC-15

Index Twist Shifter
定位旋转控制器
Left: 3 Speed/Non-index
Right: 6 / 7 speed
Material: Resin
Clamp diam: 22.2mm
Packing: 50sets/ctn, 47x25x25cm,
G.W.: 14kgs
左边: 3速/非定位 右边: 6 / 7 速
材质: 树脂 安装直径: 22.2mm



LXC-22

Single Index Grip Shifte
单定位旋转控制器
Left: Non-index Right: 6 / 7 speed
Material: Resin Clamp diam: 22.2mm
Packing: 50sets/ctn, 47x25x25cm
G.W.: 14kgs
左边: 非定位 右边: 6 / 7 速
材质: 树脂 安装直径: 22.2mm



LXC-25

Friction Grip Shifter
摩擦式旋转控制器
Material: Resin
Clamp diam: 22.2mm
Packing: 50sets/ctn, 47x25x25cm,
G.W.: 13.5kgs
材质: 树脂
安装直径: 22.2mm



LXC-32

Friction Grip Shifter
摩擦式旋转控制器
Material: Resin
Clamp diam: 22.2mm
Packing: 50sets/ctn, 47x25x25cm
G.W.: 13.5kgs
材质: 树脂
安装直径: 22.2mm



LXC-07

Friction Grip Shifter
摩擦式旋转控制器
Material: Resin
Clamp diam: 22.2mm
Packing: 50sets/ctn, 47x25x25cm
G.W.: 13.5kgs
材质: 树脂
安装直径: 22.2mm



LXC-08

Friction Grip Shifter
摩擦式旋转控制器
Material: Resin
Clamp diam: 22.2mm
Packing: 50sets/ctn, 47x25x25cm
G.W.: 13.5kgs
材质: 树脂
安装直径: 22.2mm



LX5-15

MTB/ATB Non-Index Thumb Shifter
MTB/ATB非定位调速控制器
Material: Resin
Clamp diam: 22.2mm
Packing: 100sets/ctn
47x25x22cm
G.W.: 13kgs
材质: 树脂
安装直径: 22.2mm



LX5-16

MTB/ATB Non-Index Thumb Shifter
MTB/ATB非定位调速控制器
Material: Resin
Clamp diam: 22.2mm
Packing: 100sets/ctn
47x25x22cm
G.W.: 13kgs
材质: 树脂
安装直径: 22.2mm



LX5-02

MTB/ATB Friction Shifting Lever
MTB/ATB摩擦式调速控制器
Material: Resin & Steel clamp
Clamp diam: 22.2mm
Packing: 100sets/ctn
47x25x22cm
G.W.: 13kgs
材质: 树脂及钢制夹环组合
安装直径: 22.2mm



LX5-11

MTB/ATB Friction Shifting Lever
MTB/ATB摩擦式调速控制器
Material: Resin & Steel clamp
Clamp diam: 22.2mm
Packing: 100sets/ctn
47x25x22cm,
G.W.: 13kgs
材质: 树脂及钢制夹环组合
安装直径: 22.2mm



LXS-05

MTB/ATB Non-Index Thumb Shifter

MTB/ATB非定位调速控制器

Material: Alloy aluminum lever with Resin cover

Steel clamp diam: 22.2mm

Packing: 100sets/ctn

47x25x22cm

G.W.: 22kgs

材质: 铝合金手柄带树脂套, 钢制夹环

安装直径: 22.2mm



LXS-06

MTB/ATB Non-Index Thumb Shifter

MTB/ATB非定位调速控制器

Material: Alloy aluminum lever with Resin cover

Steel clamp diam: 22.2mm

Packing: 100sets/ctn

47x25x22cm

G.W.: 22kgs

材质: 铝合金手柄带树脂套, 钢制夹环

安装直径: 22.2mm



LXS-13

Friction Racing Double Shifting Lever

摩擦式赛车立管调速控制器

Material: Alloy aluminum

Clamp diam: 22.2mm

Packing: 100sets/ctn, 47x25x22cm

G.W.: 13kgs

材质: 铝合金

安装直径: 22.2mm



LXK-16
L= 75mm



LXK-01
L= 75mm



LXK-02
L= 75mm



LXK-03
L= 75mm



LXK-04
L= 75mm



LXK-05
L= 70mm



LXK-06
L= 85mm



LXK-07
L= 75 mm



LXK-08
L= 80 mm



LXK-09
L= 120 mm



LXK-10
L= 120 mm



LXK-11
L= 120 mm



LXK-12
L= 120 mm



LXK-13
L= 120 mm



LXK-14
L= 120 mm

2019

FREEWHEEL SERIES

/
GEEYA BICYCLE

No.18, Niniu Tang Rd., Shengshan, Cixi, Ningbo,

+

飞轮 系列。

沿袭欧洲标准，大型多工位冲压机，保证了国内飞轮生产高端设备的标杆地位，傲视群雄。冷锻成型，全数控加工，使变速更快、更安静、更平稳。我们提供给你的不仅仅是一枚飞轮，而是一种全新的操控体验，它源于创新的技术和虔诚的态度。

We take over the European Standard and use large multi-position punching machines to guarantee benchmark status of high end equipments to produce index freewheels in domestic. The freewheels are cold forming & CNC machining, which make transmission more quickly, quietly and smoothly. We not only supply a freewheel for you, but also give you a new controlled experience, because it implies our creative technology and religious attitude.



LXCS-11I-50T

11 Speed cassette sprockets
Ratio: 11T. 13T. 15T. 18T. 21T. 24T. 28T. 32T. 36T. 42T. 50T.
Finish: CP/Nickel/Black Chrome/Matt Silver
Lock Ring: ø38mm
Weight: 648g
10速定位卡式飞轮
表面处理: 镀铬、镀镍、黑铬、本色喷砂(浸防锈液)
齿数: 11T. 13T. 15T. 18T. 21T. 24T. 28T. 32T. 36T. 42T. 50T.
毛重: 648克



LXCS-11I-48T

11 Speed cassette sprockets
Ratio: 11T. 13T. 15T. 18T. 21T. 24T. 28T. 32T. 36T. 42T. 48T.
Finish: CP/Nickel/Black Chrome/Matt Silver
Lock Ring: ø38mm
Weight: 648g
10速定位卡式飞轮
表面处理: 镀铬、镀镍、黑铬、本色喷砂(浸防锈液)
齿数: 11T. 13T. 15T. 18T. 21T. 24T. 28T. 32T. 36T. 42T. 48T.
毛重: 648克



LXCS-10I-42T

10 Speed cassette sprockets
Ratio: 11T. 13T. 15T. 18T. 21T. 24T. 28T. 32T. 36T. 42T.
Finish: CP/Nickel/Black Chrome/Matt Silver
Lock Ring: ø38mm
Weight: 529g
10速定位卡式飞轮
表面处理: 镀铬、镀镍、黑铬、本色喷砂(浸防锈液)
齿数: 11T. 13T. 15T. 18T. 21T. 24T. 28T. 32T. 36T. 42T.
毛重: 529克



LXCS-9I-34T

9 Speed Cassette freewheel
Finish: Black/CP/Nickel
Standard:
11T/12T/14T/16T/18T/21T/24T/28T/34T
Q'TY: 50PCS
Weight: 389.6g
9速定位卡式飞轮
表面处理: 黑色/镀铬/镀镍
齿数:
11T/12T/14T/16T/18T/21T/24T/28T/34T
毛重: 389.6克



LXCS-9I-32T

7 Speed cassette sprockets
Ratio: 11T, 12T, 14T, 16T, 18T, 21T, 24T, 28T, 32T
Finish: CP/Nickel/Black Chrome/Matt Silver
Lock Ring: ø38mm
Weight: 359g
7速定位卡式飞轮
表面处理: 镀铬、镀镍、黑铬、本色喷砂
(漫防锈液)
齿数: 11T, 12T, 14T, 16T, 18T, 21T, 24T, 28T, 32T
毛重: 359克



LXCS-8I-34T/BK

8 Speed Cassette freewheel
Finish: Black/CP/Nickel
Standard:
12T/14T/16T/18T/21T/24T/28T/34T
Q'TY: 50PCS
Weight: 374.5g
8速定位卡式飞轮
表面处理: 黑色/镀铬/镀镍
齿数:
12T/14T/16T/18T/21T/24T/28T/34T
毛重: 374.5克



LXCS-8I-32T/CP

8 Speed Cassette freewheel
Finish: Black/CP/Nickel
Standard:
12T/14T/16T/18T/21T/24T/28T/32T
Q'TY: 50PCS
Weight: 374.5g
8速定位卡式飞轮
表面处理: 黑色/镀铬/镀镍
齿数:
12T/14T/16T/18T/21T/24T/28T/32T
毛重: 374.5克



LXCS-7I-28T

7 Speed cassette sprockets
Ratio: 11T, 13T, 15T, 18T, 21T, 24T, 28T
Finish: CP/Nickel/Black Chrome/Matt Silver
Lock Ring: ø38mm
Weight: 359g
7速定位卡式飞轮
表面处理: 镀铬、镀镍、黑铬、本色喷砂
(漫防锈液)
齿数: 11T, 13T, 15T, 18T, 21T, 24T, 28T
毛重: 359克



LXFW-5SICP

5 Speed Index Freewheel
5速定位飞轮
Surface finished: CP
Standard: 14/16/20/24/28T
The inner core is formed by forge cold
Packing: 50pcs/ctn, 53x21x17cm
G.W.: 21kgs
表面处理: 镀铬
标准: 14/16/20/24/28 T
内芯冷锻成形



LXFW-5SIB

5 Speed Index Freewheel
5速定位飞轮
Surface finished: Brown
Standard: 14/16/20/24/28T
The inner core is formed by forge cold
Packing: 50pcs/ctn, 53x21x17cm
G.W.: 21kgs
表面处理: 棕色
标准: 14/16/20/24/28 T
内芯冷锻成形



LXFW-5SIB/BK

5 Speed Index Freewheel
5速定位飞轮
Surface finished: Brown+Black
The inner core is formed by forge cold
Packing: 50pcs/ctn, 53x21x17cm
G.W.: 21kgs
表面处理: 棕色+发黑
标准: 14/16/20/24/28 T
内芯冷锻成形



LXFW-6SICP

6 Speed Index Freewheel
6速定位飞轮
Surface finished: CP
Standard: 14 / 16 / 18 / 21 / 24 / 28 T
The inner core is formed by forge cold
Packing: 50pcs/ctn, 53x21x18cm
G.W.: 23kgs
表面处理: 镀铬
标准: 14 / 16 / 18 / 21 / 24 / 28 T
内芯冷锻成形



LXFW-6SIB

6 Speed Index Freewheel
6速定位飞轮
Surface finished: Brown
Standard: 14 / 16 / 18 / 21 / 24 / 28 T
The inner core is formed by forge cold
Packing: 50pcs/ctn, 53x21x18cm
G.W.: 23kgs
表面处理: 棕色
标准: 14 / 16 / 18 / 21 / 24 / 28 T
内芯冷锻成形



LXFW-6SIB/BK

6 Speed Index Freewheel
6速定位飞轮
Surface finished: Brown+Black
Standard: 14 / 16 / 18 / 21 / 24 / 28 T
The inner core is formed by forge cold
Packing: 50pcs/ctn, 53x21x18cm
G.W.: 23kgs
表面处理: 棕色+发黑
标准: 14 / 16 / 18 / 21 / 24 / 28 T
内芯冷锻成形



LXFW-7SICP

7 Speed Index Freewheel
7速定位飞轮
 Surface finished: CP
 Standard: 14 / 16 / 18 / 20 / 22 / 24 / 28 T
 The inner core is formed by forge cold
 Packing: 50pcs/ctn, 53x21x19cm
 G.W.: 25kgs
 表面处理: 镀铬
 标准: 14 / 16 / 18 / 20 / 22 / 24 / 28 T
 内芯冷锻成形



LXFW-7SIB

7 Speed Index Freewheel
7速定位飞轮
 Surface finished: Brown
 Standard: 14 / 16 / 18 / 20 / 22 / 24 / 28 T
 The inner core is formed by forge cold
 Packing: 50pcs/ctn, 53x21x19cm
 G.W.: 25kgs
 表面处理: 棕色
 标准: 14 / 16 / 18 / 20 / 22 / 24 / 28 T
 内芯冷锻成形



LXFW-7SIB/BK

7 Speed Index Freewheel
7速定位飞轮
 Surface finished: Brown+Black
 Standard: 14 / 16 / 18 / 20 / 22 / 24 / 28 T
 The inner core is formed by forge cold
 Packing: 50pcs/ctn, 53x21x19cm
 G.W.: 25kgs
 表面处理: 棕色+发黑
 标准: 14 / 16 / 18 / 20 / 22 / 24 / 28 T
 内芯冷锻成形



LXFW-7SIACP

7 Speed Index Freewheel
7速定位飞轮
Surface finished: CP
Standard: 14 / 16 / 18 / 20 / 22 / 24 / 34T
The inner core is formed by forge cold
Packing: 20pcs/ctn, 60x25x9cm
G.W.: 12kgs
表面处理: 镀铬
标准: 14 / 16 / 18 / 20 / 22 / 24 / 34T
内芯冷锻成形



LXFW-7SIAB/BK

7 Speed Index Freewheel
7速定位飞轮
Surface finished: Brown+Black
Standard: 14 / 16 / 18 / 20 / 22 / 24 / 34 T
The inner core is formed by forge cold
Packing: 20pcs/ctn, 60x25x9cm
G.W.: 12kgs
表面处理: 棕色+发黑
标准: 14 / 16 / 18 / 20 / 22 / 24 / 34 T
内芯冷锻成形



LXFW-8SIB

8 Speed Index Freewheel
8速定位飞轮
Surface finished: Brown
Standard: 13-28 T
The inner core is formed by forge cold
Packing: 50pcs/ctn, 53x21x20cm
G.W.: 27kgs
表面处理: 棕色
标准: 13-28 T
内芯冷锻成形



LXFW-8SIAUCP/BK

8 Speed Index Freewheel
8速定位飞轮
Surface finished: UCP+Black
Standard: 13-34 T
The inner core is formed by forge cold
Packing: 20pcs/ctn, 60x25x9cm
G.W.: 12kgs
表面处理: 镀锌+发黑
标准: 13-34 T
内芯冷锻成形



LXFW-8SICP

8 Speed Index Freewheel
8速定位飞轮
Surface finished: CP
Standard: 13-28 T
The inner core is formed by forge cold
Packing: 50pcs/ctn, 53x21x20cm
G.W.: 27kgs
表面处理: 镀铬
标准: 13-28 T
内芯冷锻成形



LXFW-8SIB/BK

8 Speed Index Freewheel
8速定位飞轮
Surface finished: Brown+Black
Standard: 13-28 T
The inner core is formed by forge cold
Packing: 50pcs/ctn, 53x21x20cm
G.W.: 27kgs
表面处理: 棕色+发黑
标准: 13-28 T
内芯冷锻成形



LXFW-9SICP

9 Speed Index Freewheel

9速定位飞轮

Surface finished: CP

Standard: 13-32 T

The inner core is formed by forge cold

Packing: 50pcs/ctn, 53x21x21cm

G.W.: 29kgs

表面处理: 镀铬

标准: 13-32 T

内芯冷锻成形



LXFW-9SIBK

9 Speed Index Freewheel

9速定位飞轮

Surface finished: Black

Standard: 13-32 T

The inner core is formed by forge cold

Packing: 50pcs/ctn, 53x21x21cm

G.W.: 29kgs

表面处理: 发黑

标准: 13-32 T

内芯冷锻成形



LXFW-5CP

5 Speed Index Freewheel
5速定位飞轮, 适合公路车。
Surface finished: CP
Standard: 14/16/18/21/24T
The inner core is formed by forge cold
Packing: 50pcs/ctn, 53x21x17cm
G.W.: 21kgs
表面处理: 镀铬
标准: 14/16/18/21/24T
内芯冷锻成形



LXFW-6CP

6 Speed Index Freewheel
6速定位飞轮适合公路车。
Surface finished: CP
Standard: 14 / 16 / 18 / 20 / 22/ 24T
The inner core is formed by forge cold
Packing: 50pcs/ctn, 53x21x18cm
G.W.: 23kgs
表面处理: 镀铬
标准: 14 / 16 / 18 / 20 / 22/ 24T
内芯冷锻成形



LXFW-5B/BK

5 Speed Index Freewheel
5速定位飞轮适合公路车。
Surface finished: Brown+Black
Standard: 14/16/18/21/24T
The inner core is formed by forge cold
Packing: 50pcs/ctn, 53x21x17cm
G.W.: 21kgs
表面处理: 棕色+发黑
标准: 14/16/18/21/24T
内芯冷锻成形



LXFW-6B/BK

6 Speed Index Freewheel
6速定位飞轮适合公路车。
Surface finished: Brown+Black
Standard: 14 / 16 / 18 / 20 / 22/ 24T
The inner core is formed by forge cold
Packing: 50pcs/ctn, 53x21x18cm
G.W.: 23kgs
表面处理: 棕色+发黑
标准: 14 / 16 / 18 / 20 / 22/ 24T
内芯冷锻成形



LXFW-55

5 Speed Friction Freewheel

5速不定位飞轮

Surface finished: CP / Black / Brown

Standard: 14/17/20/24/28T

Size: 1/2" x 3/32"

The inner core is formed by forge cold

Packing: 50pcs/ctn, 44x21x16cm

G.W.: 21kgs

表面处理: 镀铬 / 发黑 / 棕色

标准: 14/17/20/24/28 T

尺寸: 1/2" x 3/32"



LXFW-65

6 Speed Friction Freewheel

6速不定位飞轮

Surface finished: CP / Black / Brown

Standard: 14/16/18/21/24/28T

Size: 1/2" x 3/32"

The inner core is formed by forge cold

Packing: 50pcs/ctn, 44x21x17cm

G.W.: 22.5kgs

表面处理: 镀铬 / 发黑 / 棕色

标准: 14/16/18/21/24/28T

尺寸: 1/2" x 3/32"



LXFW-75

7 Speed Friction Freewheel

7速不定位飞轮

Surface finished: CP / Black / Brown

Standard: 14/16/18/21/24/28T

Size: 1/2" x 3/32"

The inner core is formed by forge cold

Packing: 50pcs/ctn, 44x21x17cm

G.W.: 22.5kgs

表面处理: 镀铬 / 发黑 / 棕色

标准: 14/16/18/21/24/28T

尺寸: 1/2" x 3/32"



FW-16T

Size: 1/2" x 1/8", BC1.375-24TRI-6H,M35x1-6H

Finish: Black, Brown, CP.

Packing: 100PCS/CTN

G.W./N.W.: 20/19 kg

规格: 1/2" x 1/8", BC1.375-24TRI-6H,M35x1-6H

表面处理: 发黑, 发黄, 镀铬

包装: 100只/箱

毛重: 20千克 净重: 19千克



FW-18T

Size: 1/2" x 1/8", BC1.375-24TRI-6H,M35x1-6H

Finish: Black, Brown, CP.

Packing: 100PCS/CTN

G.W./N.W.: 20/19 kg

规格: 1/2" x 1/8", BC1.375-24TRI-6H,M35x1-6H

表面处理: 发黑, 发黄, 镀铬

包装: 100只/箱

毛重: 20千克 净重: 19千克



2019

BRAKE SETS

/

GEEYA BICYCLE

No.18, Niniu Tang Rd., Shengshan, Cixi, Ningbo,

+

闸器 系列。

|

强大的刹车力和极好的刹车控制。

POWERFUL BRAKE FORCE AND EXCELLENT BRAKE CONTROL.



LXD-B108

Brake lever for racing bicycle
赛车用闸把
Material: Aluminum Alloy & Steel
packing: 100prs/ctn
43x22x22cm
G.W: 16kgs
铝合金及钢制组合



LXD-B109

Brake Lever
闸把
Material: Aluminum Alloy
Packing: 100prs/ctn
G.W: 13kgs
材质: 铝合金



LXD-B105

Brake Lever
闸把
Material: Aluminum alloy lever
Suitable for 3 finger
with return spring.
Packing: 100prs/ctn, 46x27x33cm
G.W.: 19kgs
材质: 铝合金指把及尼龙合成座架
适用3指式, 带回位弹簧



LXD-B106

Brake Lever
闸把
Material: Aluminum alloy lever
Suitable for 2-3 finger
with return spring.
Packing: 100prs/ctn, 46x27x33cm
G.W.: 20kgs
材质: 铝合金指把及尼龙合成座架
适用2-3指式, 带回位弹簧

**LXD-201****Brake Lever**

闸把

Material: Nylon with steel insertion lever
& Nylon bracketSuitable for 2-3 finger
with return spring.

Packing: 100prs/ctn

46x27x33cm

G.W.: 18kgs

材质：尼龙钢芯合成指把及尼龙座架
适用2-3指式，带回位弹簧**LXD-204****Brake Lever**

闸把

Material: Nylon with steel insertion lever
& Nylon bracketSuitable for 3-4 finger
with return spring.

Packing: 100prs/ctn

46x27x33cm,

G.W.: 19kgs

材质：尼龙钢芯合成指把及尼龙座架
适用3-4指式，带回位弹簧**LXD-204A****Brake Lever**

闸把

Material: Nylon with steel insertion lever
& Nylon bracketSuitable for 2-3 finger
with return spring.

Packing: 100prs/ctn

46x27x33cm,

G.W.: 19kgs

材质：尼龙钢芯合成指把及尼龙座架
适用2-3指式，带回位弹簧



LXV-19

V- Brake Arms
V型闸
Material: Light alloy
Dual spring tension adjustment
Arm length: 110mm Brake shoes: 50 / 60 / 70 mm
Surface finished: Silver / yellow / red / blue etc
Packing: 50sets/ctn, 36x26x27cm G.W.: 19kgs
材质: 轻合金
双重弹簧拉紧调节
臂长: 110mm
闸皮长度: 50 / 60 / 70 mm
表面处理: 银色 / 黄色 / 红色 / 蓝色等



LXV-15

V- Brake Arms
V型闸
Material: Nylon with Steel- reinforced insertion
Dual spring tension adjustment
Arm length: 112mm
Brake shoes: 50 / 60 / 70 mm
Packing: 50sets/ctn, 36x26x27cm G.W.: 23kgs
材质: 尼龙增强钢芯合成
双重弹簧拉紧调节
臂长: 112mm
闸皮长度: 50 / 60 / 70 mm



LXV-13

V- Brake Arms
V型闸
Material: Steel-reinforced
Dual spring tension adjustment
Arm length: 110mm
Brake shoes: 50 / 60 / 70 mm
Surface finished: CP / ED
Packing: 50sets/ctn, 36x26x27cm
G.W.: 23kgs
材质: 增强钢制
双重弹簧拉紧调节
臂长: 110mm
闸皮长度: 50 / 60 / 70 mm
表面处理: 镀铬 / 电泳



LXV-17

V- Brake Arms
V型闸
Material: Nylon with
Steel- reinforced insertion
Dual spring tension adjustment
Arm length: 110mm
Brake shoes: 50 / 60 / 70 mm
Packing: 50sets/ctn, 36x26x27cm G.W.: 23kgs
材质: 尼龙增强钢芯合成
双重弹簧拉紧调节
臂长: 110mm
闸皮长度: 50 / 60 / 70 mm

**LXE-2000**

Caliper Brake Arms
钳型闸
Material: Light alloy
Side pull
Color: to order
Center distance: 38-52mm
Packing: 50sets/ctn, 44x30x23.5cm
G.W.: 23.5kgs
材质: 轻合金
侧拉式
颜色: 按需所定
中心距: 38-52mm

**LXE-2003**

Caliper Brake Arms
钳型闸
Material: Light alloy
Side pull
Color: to order
Center distance: 38-52mm
Packing: 50sets/ctn, 44x30x23.5cm
G.W.: 23.5kgs
材质: 轻合金
侧拉式
颜色: 按需所定
中心距: 38-52mm

**LXE-2001**

Caliper Brake Arms
钳型闸
Material: Light alloy
Side pull
Color: to order
Center distance: 47-61mm
Packing: 50sets/ctn, 52x29x31cm
G.W.: 19kgs
材质: 轻合金
侧拉式
颜色: 按需所定
中心距: 47-61mm

**LXE-75**

Caliper Brake Arms
钳型闸
Material: Steel-reinforced
Side pull
Surface finished: CP / ED
Packing: 50sets/ctn, 52x29x25cm
G.W.: 24kgs
材质: 增强钢制
侧拉式
表面处理: 镀铬 / 电泳



LX0-01



LX0-02



LX0-03



LX0-04



LX0-05



LX0-06



LX0-07



LXN-01



LXN-02



LXN-03



LXN-04



LXN-05



E01



E02



E03



E04



E05



E06



E07



E08



E09



E10



E11



E12



E13



E14



OUTER CABLE 线管



慈溪市捷雅车业有限公司

CIXI GEEYA BICYCLE CO., LTD.

(原慈溪市羚翔车业有限公司)

地址：中国·宁波慈溪市胜山工业区泥牛塘路 18 号

ADD.: No.18, Niniu Tang Rd., Shengshan Industrial Zone, Cixi City, Ningbo, China

Tel: 0086-574-58962851 013906740877

Fax: 0086-574-63547728 63548276 P.C.: 315323

E-mail: lingxiang@china-lingxiang.com

Jieya@china-lingxiang.com

<http://www.china-lingxiang.com>

天津办事处 Tianjin Office

地址：天津市北辰区青光镇青光工业园福源路 10 号 3 排 3 号

联系人：罗先生

电话：13516118588

